

Model H800AJ

HYBRID ARTICULATING BOOM LIFTS



MORE ECONOMIC

- Hybrid diesel and electric technology for low emissions and noise.

MORE PRODUCTIVE

- Get access to work any job site environment in respect of the regulations, inside and outside.

MORE ACCESS

- Conquer rough terrain with standard oscillating axle and four-wheel drive, delivering optimised grip and stability.

SMART DESIGN

- Reduce maintenance with an all steel turntable hood to protect components.



Standard Features

- 0.91 m x 1.83 m low mount platform
- Side entry with drop bar mid rail
- Multiple function operation
- Full proportional drive joystick control with integral thumb steer switch
- Full proportional main boom and swing joystick control
- Multiple speed control for telescope, lower boom and platform rotate
- Selectable creep speed on drive/lift and swing functions
- 1.83 m articulating jib
- 180 degree powered platform rotator
- Platform console machine status light panel ¹
- Load sensing system
- AC power cable to platform
- Engine distress warning/shut down system ²
- Gull-wing turntable hoods
- Swing-out engine tray
- Control ADE® (Advanced Design Electronics) System
- Hydrostatic drive transmission
- Four wheel drive
- Horn
- Automatic Engine Idle, Start/Stop
- Automatic Battery Charger in Hybrid Mode
- QuikStik® boom design
- 4 degree tilt alarm and indicator light
- Oscillating front axle
- Load sensing boom function pump
- Lifting/tie down lugs
- Hour meter
- Ground control selector switch with key lock
- Skyguard without beacon
- Platform tool tray
- 220V-AC 15A Charging Cable
- Platform/Ground display battery SOC indicator

¹ Provides indicator lights at platform control console for system distress, low fuel, tilt light, battery charge indicator and foot switch status.

² Low oil pressure and high coolant temperature alarms with shut-down enabled/disabled by analyser.

Standard Specifications

Power	
• Diesel Engine	
• Kubota Tier 4 Final:	18.6 kW (25p)
• Motor/ Generator Power:	20.9 kW (28hp)
• Fuel Tank Capacity	94.6L
• Batteries	12V, 235 Ah, 4D, AGM Maintenance Free
• System Voltage	84V DC
• Battery Quantity	14
Tyres	
• Tyres	18 - 625 Foam Filled
Hydraulic System	
• Hydraulic capacity	79,5 L

Accessories & Options

- 0.91 m x 2.44 m low mount platform
- Side entry with inward swing gate
- 13 mm air line to platform
- 18 - 625 foam filled non marking
- On-board 4,000W generator
- SkyPower® package 7,500 watt on-board generator
- SkyWelder® package 250 amp welder in the platform ³
- All motion alarm
- Light package ⁴
- Platform flood lights
- Platform worklights
- Head and tail lights
- Flashing amber beacon
- Plugs & Sockets
- Hostile environment package ⁵
- Skyguard with beacon
- Corner storage tray
- Cold weather package ⁶
- Soft Touch System
- Fall Arrest Platform (0.91 x 2.44 m)
- Fire extinguisher
- Synthetic Biodegradable Hydraulic Oil
- Special paint colour

³ Available when integrated with the SkyPower® package.

⁴ Includes platform mounted work lights and head & tail lights.

⁵ Includes console cover, boom wipers and cylinder bellows.

⁶ Includes a battery blanket, hydraulic tank heater, block heater and glow plugs (diesel only).

Model H800AJ

HYBRID ARTICULATING BOOM LIFTS

Performance

• Working Height	26.38 m
• Platform Height	24.38 m
• Horizontal Outreach	15.80 m
• Working Outreach	16.45 m
• Up and Over Height	9.78 m
• Swing (Continuous)	360°
• Platform Capacity - Unrestricted	👤/230 kg
• Platform Rotator (Hydraulic)	180°
• Jib - Overall Length	1.83 m
• Jib - Range of articulation	130° (+70°/-60°)
A. Platform Size	0.91 m x 1.83 m
B. Overall Width	2.49 m
C. Tailswing - working condition	1.06 m
D. Stowed Height	3.00 m
E. Stowed Length	11.13 m
F. Wheelbase	3.06 m
G. Ground Clearance	0.28 m
• Machine weight ¹	16,110 kg
• Maximum Ground Bearing Pressure	5.3 kg/cm ²
• Drive Speed 4WD	5.55 km/h
• Gradeability 4WD	45%
• Turning Radius - Inside 2WS	3.81 m
• Turning Radius - Outside 2WS	6.02 m

¹ Certain options or country standards may increase weight and/or dimensions.



Reach Diagram

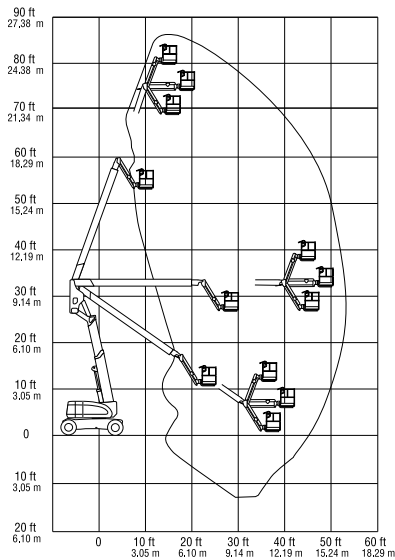

Dimensions

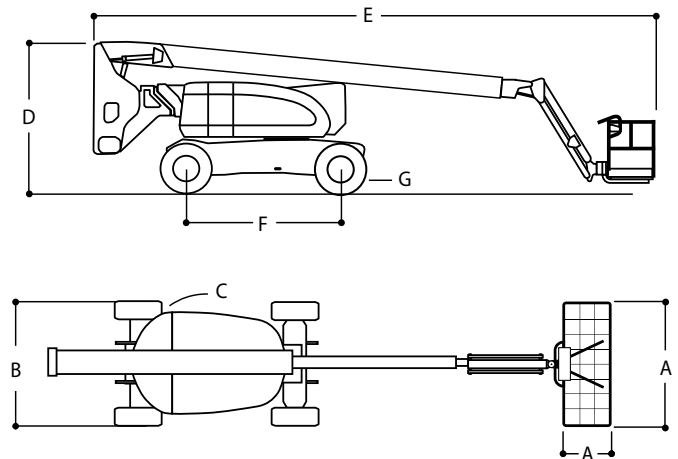

IMPORTANT

JLG is continually researching and developing products and reserves the right to make modifications without prior notice. All data in this document is indicative. Certain options or country standards will increase weight. Specifications may change to meet country standards or with the addition of optional equipment.

Due to continuous product improvements, JLG Industries reserves the right to make specification and/or equipment changes without prior notification.



JLG EMEA BV

Polaris Avenue 63
2132 JH Hoofddorp
The Netherlands
Phone: +31 (0)23 565 5665
www.jlg.com

An Oshkosh Corporation Company